

# "SAN ACE 200"

Kikuo Miyahara

Minoru Fujiwara

Tomoaki Ikeda

---

## 1. Introduction

---

The amount of heat generated by a general-purpose computer has been increasing as the CPU speed continues to rise and parts are packed more densely in compact packages. Large-scale computers in particular are obliged to use forced cooling such as a liquid cooling system. The indirect type of liquid cooling system typically uses water, which has a higher thermal conductivity and a high specific heat value. However, the use of water as a cooling medium imposes restrictions on installation location due to the need for a supply of cooling water, and also a high degree of liquid tightness is essential.

We have developed a large-size air cooling fan "SAN ACE 200" with improved cooling performance that overcomes these problems.

This report describes the outline and features of the product.

---

## 2. Background of Development

---

We developed and have been manufacturing "DC DYNA ACE" that has a diameter of 172 mm and is ideal for cooling large equipment. In the past, forced cooling by a liquid cooling system was used for large equipment such as general-purpose computers because of its high cooling performance even after various measures to decrease heat had been taken. Because cooling by a liquid cooling system restricts the installation location and makes the structure complex, the equipment is expensive. Furthermore, noise worsened as the speed of rotation of conventional "DC DYNA ACE" was increased to achieve the necessary cooling performance. We have therefore developed and released large-size "SAN ACE 200" fan that offers both low-noise operation and higher cooling performance.

---

## 3. Features of "SAN ACE 200"

---

[Fig. 1](#) shows the outside view of "SAN ACE 200".

The cooling fan uses a three-phase bipolar high-efficiency motor and is designed for large equipment such as general-purpose computers.

The main features of this product are shown below.

- (1) Highly efficient design using three-phase bipolar motor
- (2) Low-noise design after assembly into equipment
- (3) High reliability
- (4) Two-step speed selection: high-speed rotation or low-speed rotation
- (5) Stable rotating speed under voltage deviation with speed control circuit
- (6) Monitoring of rotation speed from the pulse sensor output

### 3.1 Dimensions and Specifications

[Fig. 2](#) shows the dimensions and specifications of "SAN ACE 200".

### 3.2 General Characteristics

Table 1 shows the general characteristics of "SAN ACE 200".

**Table 1 General characteristics of "SAN ACE 200".**

Model number:109E2024AS001

| Rotating condition                                  | High-speed rotation | Low-speed rotation |
|---|---------------------|--------------------|
| Rated voltage (V)                                   | 24                  |                    |
| Operating voltage range (V)                         | 21.6 to 26.4        |                    |
| Rated current (A)                                   | 1.9                 | 1.2                |
| Rated rotation speed (min <sup>-1</sup> )           | 3200                | 2800               |
| Maximum air volume (m <sup>3</sup> /min)            | 10.45               | 9                  |
| Maximum static pressure(Pa)<br>{mmH <sub>2</sub> O} | 287.1<br>{29.3}     | 217.5<br>{22.1}    |
| Acoustic noise (dB[A])                              | 57                  | 54                 |
| Mass (kg)   | 1.8                 |                    |

### 3.3 Air Volume versus Static Pressure Characteristics

[Fig. 3](#) shows an example of the characteristics of air volume versus static pressure of "SAN ace 200".

The improvement in cooling performance compared with conventional "DC DYNA ACE" is about 2.1 times for the maximum static pressure and about 1.6 times for the maximum air volume.

### 3.4 Speed Selection Function

Either high-speed rotation or low-speed rotation can be selected with the control leads.

Table 2 shows the speed control specifications.

**Table 2 Control specifications**

| Control lead  | Rotating condition  |
|---------------|---------------------|
| Hi. level     | High-speed rotation |
| Lo. level     | Low-speed rotation  |
| Hi. impedance | High-speed rotation |

For example, with this function low-speed rotation can be selected when the ambient temperature is low and internal heating is small because the reduced cooling will not cause problems. Low-speed rotation also reduces acoustic noise and power consumption. If there is no constraint on space, the number of fans can be increased, enabling low-speed rotation to be used during normal operation for low noise, and high-speed rotation to be used in case one of the fans fails and the temperature starts to rise.

### 3.5 Voltage versus Rotation Speed

[Fig. 4](#) shows an example of the voltage versus rotation speed of "SAN ACE 200". In the voltage range of about 20 V and higher, amount of the rotation speed change of less than about 20 min<sup>-1</sup>/V is realized during both the high-speed rotation and low-speed rotation, thanks to the speed control circuit. As the change of cooling performance against voltage fluctuations is small, the thermal design is much easier.

As the increase in the rotation speed is smaller even when the supply voltage rises above the rated voltage, the increase in acoustic noise is small.

---

#### **4. Conclusions**

---

We have briefly described the structure and performance of "SAN ACE 200". Large equipment in the future will offer higher performance and have higher packing density, resulting in higher heating density. There will thus be a great demand for highly efficient cooling fans such as "SAN ace 200". The cost-performance of final products can be improved by lowering the power consumption of semiconductors, optimizing the heating reduction design and by using "SAN ace 200".

---

Kikuo Miyahara  
Joined company in 1983  
Cooling Systems Division, Design Dept.  
Worked on development and design of "SAN ACE 200"

Minoru Fujiwara  
Joined company in 1981  
Cooling Systems Division, Design Dept.  
Worked on development and design of "SAN ACE 200" after working on development of servo amplifiers

Tomoaki Ikeda  
Joined company in 1990  
Cooling Systems Division, Design Dept.  
Worked on development and design of "SAN ACE 200"

---

Fig.1 Outside view of "SAN ace 200"



Fig.2 Dimensions and specifications of "SAN ace 200"

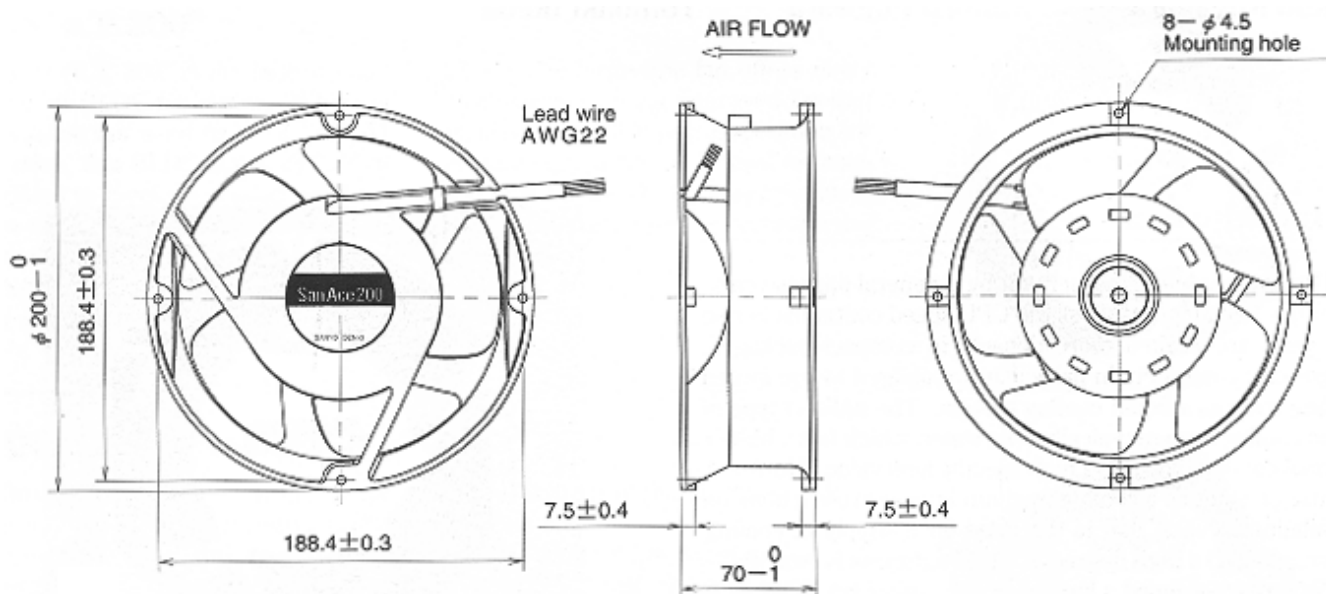

Fig.3 Example of air volume versus static pressure of "SAN ace 200"

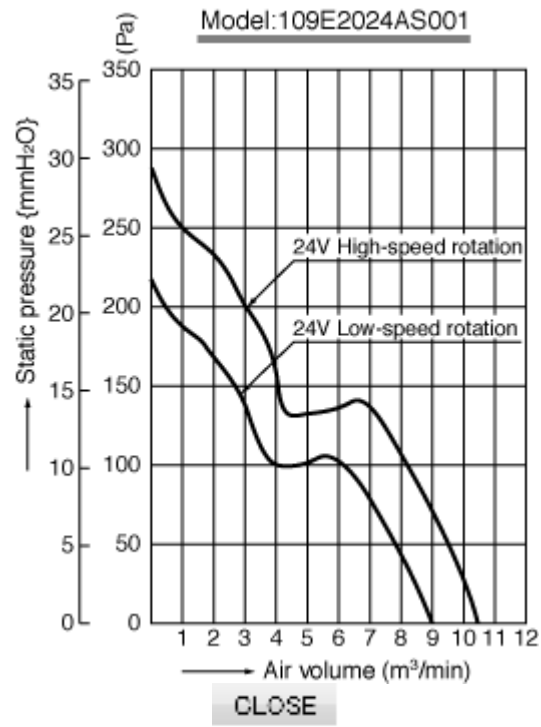

Fig.4 Example of voltage versus rotation speed of "SAN ace 200"

